



2. Press SOUND to hear the first sound of the game.
3. Then press any keypad button.
  - If the sound on the keypad button matches the sound on the SOUND button, you've got a match! The keypad button lights up and your turn continues. Press the SOUND button again to reveal a new sound. Then press another keypad button with the hope of finding another match. Your turn continues as long as you continue to match sounds.
  - If the sound on the keypad button does not match the sound on the SOUND button, your turn is over. Try to remember which keypad button activates which sound. That way you can find it later in the game.
4. The computer takes its turn by automatically pressing the SOUND button and a keypad button. If the computer gets a match, its turn continues. If not, you begin a new turn.

### Winning the Game

Be first to match four sounds in a row – across, up and down, or diagonally on the keypad. All four lights will flash, the last sound will play, and the keypad will light up to announce your victory. Press START to begin another game.

### Challenge Your Friends

Slide the GAME SELECTION button to "Multi" to play a multi-player game. Then press START. You may challenge any number of players, with each player taking a turn in order. The computer does not play in this version.

### Enjoy the Sound Effects

Slide the GAME SELECTION button to "Freestyle." Press START and then simply press different keypad buttons to hear your favorite Simpsons sounds and expressions. There are 19 different sounds but only 16 keypad buttons. After listening to the first 16, press START again to "reshuffle" the sounds. Then see if you can find the three sounds you missed the first time!

### Automatic Shut Off

Your game unit will shut off automatically after three minutes of non-use.

### Important

- If this game malfunctions or "locks up," slide the ON/OFF button a few times. If the game still doesn't function, remove and replace the batteries with fresh ones
- Please keep these instructions for future reference.

### Object of the Game

Be first to match four funny Simpsons sounds in a row – either across, up and down, or diagonally on the keypad.

### A Look at the Game Unit

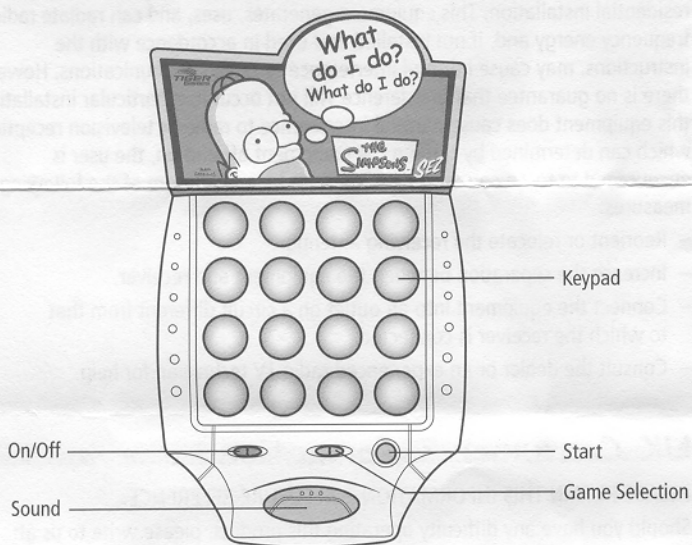

- ON/OFF** – Slide right or left to turn the game on or off.
- START** – Press to start the game.
- GAME SELECTION** – Slide left, center, or right to select type of game.
- SOUND** – Press to hear a sound.
- KEYPAD** – Press one of the 16 buttons to find a matching sound.

### Batteries

#### 3 "AA / LR6" SIZE BATTERIES ARE INCLUDED

To replace the batteries, do the following:

1. Use a Phillips head screwdriver to loosen the screw on the battery compartment on the back of the unit and open the door.
2. Carefully remove the old batteries.
3. Insert 3 new "AA / LR6" size batteries, making sure that the "+" and "-" are aligned as shown.
4. Replace the battery compartment door and tighten the screw.

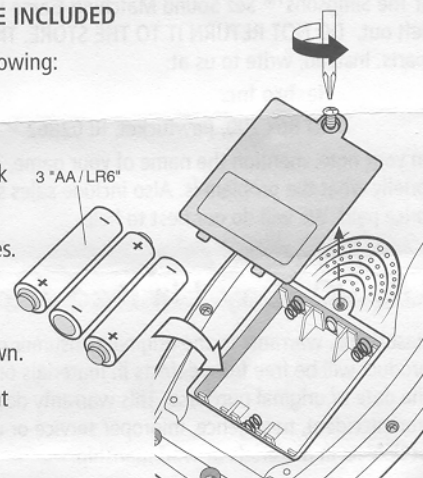

### Get Ready to Play

1. Slide ON/OFF switch to the right to turn on the game.
2. Choose a game by doing one of the following:
  - Slide the GAME SELECTION switch to the left position (Single) to play against the computer.
  - Slide the GAME SELECTION switch to the center position (Multi) to play a multi-player game.
  - Slide the GAME SELECTION switch to the right position (Freestyle) to hear the various sound effects and expressions in the game. (See Sound Effects section later in the rules for details.)

### Play Against the Computer – One on One

1. Press START. The theme music will play and the keypad will flash. All The Simpsons sounds are silently and randomly "shuffled" beneath the keypad buttons for each game.

### IMPORTANT: BATTERY INFORMATION

Please retain this information for future reference. Batteries should be replaced by an adult.

#### CAUTION:

1. Always follow the instructions carefully. Use only batteries specified and be sure to insert them correctly by matching the + and - polarity markings.
2. Do not mix old batteries and new batteries, or standard (carbon-zinc) with alkaline batteries.
3. Remove exhausted or dead batteries from the product.

4. Remove batteries if product is not to be played with for a long time.
5. Do not short-circuit the supply terminals.
6. Should this product cause, or be affected by, local electrical interference, move it away from other electrical equipment. Reset (switching off and back on again or removing and re-inserting batteries) if necessary.
7. **RECHARGEABLE BATTERIES:** Do not mix these with any other types of battery. Always remove from the product before recharging. Recharge batteries under adult supervision. **DO NOT RECHARGE OTHER TYPES OF BATTERY.**
8. As with all small items, these batteries should be kept away from children. If swallowed, seek medical attention immediately.
9. Do not dispose of batteries in fire. Battery may explode or leak.
10. As with all small batteries, the batteries used with this toy should be kept away from small children who still put things in their mouths. If they are swallowed, promptly see a doctor and have the US doctor phone (202) 625-3333 collect. UK consult their own GP.
11. Make sure the batteries are inserted correctly and follow the toy and battery manufacturer's instructions.

### Assistance

- Handle the game carefully.
- Store the game away from dusty or dirty areas.
- Keep the game away from moisture or temperature extremes.
- Do not disassemble the game. If a problem occurs, remove and replace the batteries to reset the computer.

### Defective Damage

If The Simpsons™ Sez Sound Matching Game is damaged or something has been left out, **DO NOT RETURN IT TO THE STORE.** The store doesn't have replacement parts. Instead, write to us at:

**Hasbro Inc.**

PO Box 200, Pawtucket, RI 02862

In your note, mention the name of your game, its model number, and tell us briefly what the problem is. Also include sales slip, date, place of purchase and price paid. We will do our best to help.

### Warranty

Hasbro Inc. warrants to the original consumer purchaser of this product that the product will be free from defects in materials or workmanship for 90 days from the date of original purchase. This warranty does not cover damages resulting from accident, negligence, improper service or use or other causes not arising out of defects in materials or workmanship.

During this 90-day warranty period, the product will either be repaired or replaced (at Hasbro's option) without charge to the purchaser, when returned with proof of the date of purchase to either the dealer or to Hasbro. Product returned to Hasbro without proof of the date of purchase or after the 90-day warranty period has expired, but prior to one year from the original date of purchase, will be repaired or replaced (at Hasbro's option) for a service fee of U.S. \$9.10. Payments must be by check or money order payable to Hasbro Inc.

The foregoing states the purchaser's sole and exclusive remedy for any breach of warranty with respect to the product. All product returned must be shipped prepaid and insured for loss or damage to:

Hasbro Inc.  
Consumer Returns A-847  
1027 Newport Ave.  
Pawtucket, RI 02862

The product should be carefully packed in the original box or other packing materials sufficient to avoid damage during shipment. Include a complete written

description of the defect, a check if product is beyond the 90-day warranty period, and your printed name, address and telephone number.

**THIS WARRANTY IS IN LIEU OF ALL OTHER WARRANTIES AND NO OTHER REPRESENTATIONS OR CLAIMS OF ANY NATURE SHALL BE BINDING ON OR OBLIGATE TIGER IN ANY WAY. ANY IMPLIED WARRANTIES APPLICABLE TO THIS PRODUCT, INCLUDING WARRANTIES OF MERCHANTABILITY AND FITNESS FOR A PARTICULAR PURPOSE, ARE LIMITED TO THE NINETY (90) DAY PERIOD DESCRIBED ABOVE. IN NO EVENT WILL TIGER BE LIABLE FOR ANY SPECIAL, INCIDENTAL, OR CONSEQUENTIAL DAMAGES RESULTING FROM POSSESSION, USE, OR MALFUNCTION OF THIS PRODUCT.**

Some states do not allow limitations as to how long an implied warranty lasts and/or exclusions or limitations of incidental or consequential damages, so the above limitations and/or exclusions of liability may not apply to you. This warranty gives you specific rights, and you may also have other rights, which vary, from state to state.

**THIS WARRANTY IS NOT APPLICABLE IN UK & DOES NOT AFFECT UK CONSUMER'S STATUTORY RIGHTS.**

### FCC Statement

This device complies with Part 15 of the FCC Rules.

Operation is subject to the following two conditions:

- (1) this device may not cause harmful interference, and
- (2) this device must accept any interference received, including interference that may cause undesired operation.

**WARNING:** Changes or modifications to this unit not expressly approved by the party responsible for compliance could void the user's authority to operate the equipment.

**NOTE:** This equipment has been tested and found to comply with the limits for a Class B digital device, pursuant to Part 15 of the FCC Rules. These limits are designed to provide reasonable protection against harmful interference in a residential installation. This equipment generates, uses, and can radiate radio frequency energy and, if not installed and used in accordance with the instructions, may cause harmful interference to radio communications. However, there is no guarantee that interference will not occur in a particular installation. If this equipment does cause harmful interference to radio or television reception, which can be determined by turning the equipment off and on, the user is encouraged to try to correct the interference by one or more of the following measures:

- Reorient or relocate the receiving antenna.
- Increase the separation between the equipment and receiver.
- Connect the equipment into an outlet on a circuit different from that to which the receiver is connected.
- Consult the dealer or an experienced radio TV technician for help.

**PLEASE RETAIN THIS INFORMATION FOR FUTURE REFERENCE.**

Should you have any difficulty operating this product, please write to us at:

Hasbro UK Ltd  
Hasbro Consumer Affairs  
PO BOX 43, Caswell Way, Newport, Wales, NP19 4YD

or telephone our Helpline on 00 800 2242 7276

**PROOF OF PURCHASE**  
**The Simpsons™ Sez**  
**Sound Matching Game**



TM The HASBRO and TIGER names and logos, and this game's shape and graphics are TM, ® & © 2002 Hasbro, Pawtucket, RI 02862. All Rights Reserved.

\*THE SIMPSONS\* are TM and © 2002 Twentieth Century Fox Film Corporation. All rights reserved.



Hasbro Canada, Longueuil, QC, Canada J4G 1G2. Please keep company details for future reference. ® denotes Reg. U.S. Pat. & TM Office

Distributed in the United Kingdom by Hasbro UK Ltd., Caswell Way, Newport, Gwent NP9 0YH. Distributed in Australia by Hasbro Australia Ltd., 570 Blaxland Road, Eastwood, NSW 2122, Australia. Tel: (02) 9874-0999. Distributed in New Zealand by Hasbro New Zealand Ltd., Albany Highways, Auckland, PO Box 100 940, North Shore Mail Centre, Auckland, New Zealand 1333. Tel: (649) 415-9916.



**HASBRO.COM**  
FOR NEW PRODUCTS AND OFFERS

PRINTED IN CHINA

200206800IWHB-01